

Waste Water Treatment

Single Shaft Screw Feeders SU

21

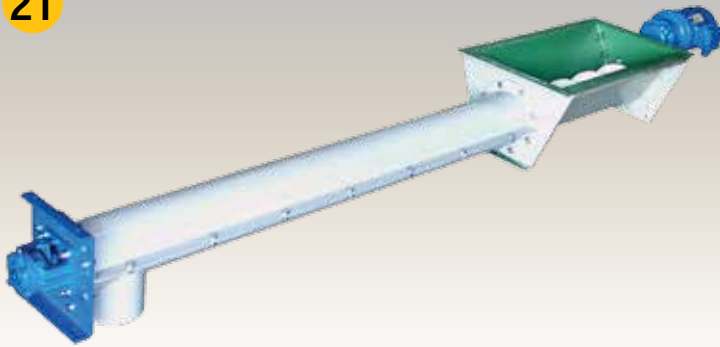

Description ▼

SU-type Single Shaft Screw Feeders are highly versatile offering numerous solutions for conveying powdery or granular materials. SU Screw Feeders are manufactured from carbon steel or stainless steel with a suitable surface finishing. The inlet section is made up from a U or V-shape trough and a tubular outlet section that is equipped with an outlet. There is an end plate at each trough end, helicoid screw flighting welded on a centre pipe with a coupling bush at each end and two end bearing assemblies complete with shaft sealing unit. Furthermore, SU Screw Feeders, which come in a medium heavy-duty design, are equipped with a gear motor that suits the application.

Function ▼

According to the cross section of the silo outlet, SU-type Single Shaft Screw Feeders are available with standard U-shaped or with flared V-section trough. For wet or dry sludge an extra heavy-duty version is available too.



Application ▼

SU Single-shafted Screw Feeders are used for discharging poorly flowing materials from hoppers or silos with a rectangular outlet.

Benefits ▼

- ✓ Prevention of bridging, rat holing and segregation and improvement of material flow;
- ✓ Maintenance-free intermediate cast hanger bearings with self-lubricating slide bushes.

Waste Water Treatment

Single Shaft Screw Feeders SU



Technical Features / Performance

- ▶ Powder-coated
- ▶ Constant feed rates
- ▶ Modular design enables easy access and individual custom-design features
- ▶ Sturdy design
- ▶ Medium-heavy-duty helicoid flighting welded on centre pipe
- ▶ Medium-heavy-duty trough in modular flanged sections
- ▶ Open trough section with drilled trough WAM® standard flange
- ▶ Round outlet with drilled WAM® standard flange
- ▶ Robust cast iron body flanged end bearing assemblies with external bearing units and manually adjustable packing gland seals
- ▶ Splined or bolted shaft couplings
- ▶ Drive units mounted at inlet or outlet end
- ▶ Direct drives in a compact version, or with coupling transmission, or with chain or belt transmission

Overall Dimensions

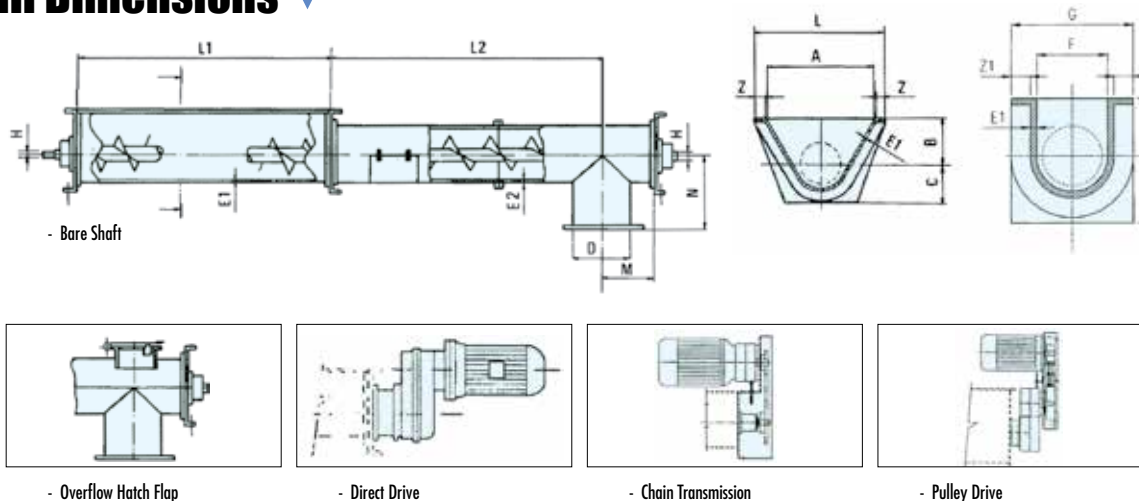

Trough screw conveyors and feeders are manufactured to the customer's requirements by means of standard components available from stock, thus enabling quick delivery.

Screw Ø	Trough U-V		Tubular trough Ø																
	L1	E1	Ø	E2	L2	A	B	C	D	F	G	H	L	M	N*	Q	Z	Z1	
100	500 750 1,000	2	114	3	VAR.	175	115	145	114	-	-	25	265	120	120	-	40	-	
120	500 750 1,000	2	139	3	VAR.	175	115	145	168	-	-	25	265	120	210	-	40	-	
150	500 750 1,000 1,250	2	168	4	VAR.	375	175	145	168	175	265	35	485	140	175	115	50	40	
200	500 750 1,000 1,250	2	219	4	VAR.	425	200	185	219	225	315	35	540	160	205	135	50	40	
250	500 750 1,000 1,250	2	273	4	VAR.	525	225	215	273	275	365	35	655	180	250	160	60	40	
300	500 1,000 1,250 1,500	3	323	4	VAR.	525	250	245	323	325	435	55	655	220	300	195	60	50	
350	1,000 1,250 1,500	3	406	5	VAR.	625	270	275	406	375	485	55	755	280	360	235	60	50	
400	1,000 1,250 1,500	3	457	5	VAR.	730	290	305	457	425	540	55	900	320	420	270	80	50	

Dimensions mm

* For cylindrical outlet (in compliance with WAM® standard)

This datasheet might not show the complete range but only the models most suitable for the application.



www.wamgroup.com